

LECICO EGYPT S.A.E
 Old Alex-Cairo Agriculture Road
 Khorshid
 358 ALEXANDRIA
 Egypt

Testing of Water closets

(3 appendices)

Assignment

At the request of Lecico Egypt S.A.E, RISE has tested three models of water closets in respect of their flushing properties. The tests are required since Lecico Egypt has installed a new distributor in the water closets. The test results will be used to revise INSTA-CERT certificate 5108 with the three tested models. Photos of the new distributor can be found in appendix 2.

Test objects

The test objects arrived to RISE 2017-11-17 and were in normal condition at arrival. Drawings of the water closets can be found in appendix 1.

Table 1

<i>Model</i>	<i>Article number</i>
Scandi I WCS , floor mounted water closet with vertical outlet (S-trap)	FS1PKW95000000
Scandi I WCP , floor mounted water closet with horizontal outlet (P-trap)	FS1PKW96000000
Scandi I WCS-Disabled , floor mounted water closet with vertical outlet (S-trap).	FS1PKW97000000

Test method

The Water Closets were tested according to NT-VVS 120:1999-11 Water Closets.

Test site and time of test

The tests were carried out at RISE Energy and circular economy in December 2017.

RISE Research Institutes of Sweden AB

Postal address	Office location	Phone / Fax / E-mail
Box 857	Brinellgatan 4	+46 10 516 50 00
SE-501 15 BORÅS	SE-504 62 BORÅS	+46 33 13 55 02
Sweden		info@ri.se

This report may not be reproduced other than in full, except with the prior written approval of the issuing laboratory.

Test equipment

Table 2

<i>Test equipment</i>	<i>SP inventory number</i>	<i>Measurement uncertainty</i>
Pressure gauge	200 722	± 0.1 bar
Pressure gauge	201 378	± 0.15 bar
Scale	201 368	± 1.5 g
Folding ruler		± 5 mm

The measurement uncertainty was calculated according to EA-4/16 with a coverage factor $k = 2$.

Result

The results are only valid for the tested objects.

When tested, all three water closets had a nominal flush that was higher than 6 litres. The volume was adjusted on the flushing valve on all three water closets. This means that Lecico also needs to adjust the volume in the water closets that are manufactured. A photo of the flushing valve with correct setting can be found in appendix 3.

Numbering of the tests in tables 3-8 corresponds to the numbering in the test method NT VVS 120.

Table 3 Scandi I WCS, main flush

<i>Test no.</i>	<i>Test method</i>	<i>Requirement</i>	<i>Scandi I WCS</i>	<i>Result</i>
Nominal Flush	NT-VVS 120			
6.4.3	Total volume of flushing water, average and max difference	Flush volume below 6 l. Tolerance of ± 0.2 litres	5.38 ± 0.05 l	Pass
6.4.4	Rinsing capacity	No sawdust left in the bowl	Ok 5 of 5 tests	Pass
6.4.5A	Flushing of toilet paper	All 12 sheets flushed out in at least 4 of 5 tests	Ok 4 of 5 tests	Pass
6.4.6A	Flushing of fifty small plastic balls	Minimum of 42 balls flushed out each time	Ok 5 of 5 tests	Pass
6.4.6B	Flushing of forty small plastic balls	Minimum of 21 balls with a mass of 2.6 g flushed out each time	Ok 5 of 5 tests	Pass
6.4.7	Flushing of sponges	All 4 sponges flushed out in at least 4 of five tests	Ok 5 of 5 tests	Pass
6.4.8	Check on splashing	Not more than eight small drops of water beyond the rim	Ok 3 of 3 tests	Pass
6.4.10	Check on water seal level	Minimum 50 mm	60 mm	Pass

Table 4 Scandi I WCS, reduced flush

<i>Test no.</i>	<i>Test method</i>	<i>Requirement</i>	<i>Scandi I WCS</i>	<i>Result</i>
Reduced flush	NT-VVS 120			
6.4.3	Total volume of flushing water, average and max difference	Flush volume below 6 l, lower than main flush. Tolerance of ± 0.3 litres	3.08 ± 0.05 l	Pass
6.4.4	Rinsing capacity	No sawdust left in the bowl	Ok 5 of 5 tests	Pass
6.4.5B	Flushing of toilet paper	All 4 sheets flushed out in at least 4 of 5 tests	Ok 4 of 5 tests	Pass
6.4.8	Check on splashing	Not more than eight small drops of water beyond the rim	Ok 3 of 3 tests	Pass
6.4.9	Exchange of water content of the trap	NaCl concentration equal to or less than 10 % of the reference concentration	< 10 %	Pass
6.4.10	Check on water seal level	Minimum 50 mm	60 mm	Pass

Table 5 Scandi I WCP, main flush

<i>Test no.</i>	<i>Test method</i>	<i>Requirement</i>	<i>Scandi I WCP</i>	<i>Result</i>
Nominal Flush	NT-VVS 120			
6.4.3	Total volume of flushing water, average and max difference	Flush volume below 6 l. Tolerance of ± 0.2 litres	5.32 ± 0.09 l	Pass
6.4.4	Rinsing capacity	No sawdust left in the bowl	Ok 5 of 5 tests	Pass
6.4.5A	Flushing of toilet paper	All 12 sheets flushed out in at least 4 of 5 tests	Ok 5 of 5 tests	Pass
6.4.6A	Flushing of fifty small plastic balls	Minimum of 42 balls flushed out each time	Ok 5 of 5 tests	Pass
6.4.6B	Flushing of forty small plastic balls	Minimum of 21 balls with a mass of 2.6 g flushed out each time	Ok 5 of 5 tests	Pass
6.4.7	Flushing of sponges	All 4 sponges flushed out in at least 4 of five tests	Ok 5 of 5 tests	Pass
6.4.8	Check on splashing	Not more than eight small drops of water beyond the rim	Ok 3 of 3 tests	Pass
6.4.10	Check on water seal level	Minimum 50 mm	61 mm	Pass

Table 6 Scandi I WCP, reduced flush

<i>Test no.</i>	<i>Test method</i>	<i>Requirement</i>	<i>Scandi I WCP</i>	<i>Result</i>
Reduced flush	NT-VVS 120			
6.4.3	Total volume of flushing water, average and max difference	Flush volume below 6 l, lower than main flush. Tolerance of ± 0.3 litres	2.80 ± 0.06 l	Pass
6.4.4	Rinsing capacity	No sawdust left in the bowl	Ok 5 of 5 tests	Pass
6.4.5B	Flushing of toilet paper	All 4 sheets flushed out in at least 4 of 5 tests	Ok 5 of 5 tests	Pass
6.4.8	Check on splashing	Not more than eight small drops of water beyond the rim	Ok 3 of 3 tests	Pass
6.4.9	Exchange of water content of the trap	NaCl concentration equal to or less than 10 % of the reference concentration	< 10 %	Pass
6.4.10	Check on water seal level	Minimum 50 mm	61 mm	Pass

Table 7 Scandi I WCS disabled, main flush

<i>Test no.</i>	<i>Test method</i>	<i>Requirement</i>	<i>Scandi I WCP</i>	<i>Result</i>
Nominal Flush	NT-VVS 120			
6.4.3	Total volume of flushing water, average and max difference	Flush volume below 6 l. Tolerance of ± 0.2 litres	5.40 ± 0.02 l	Pass
6.4.4	Rinsing capacity	No sawdust left in the bowl	Ok 5 of 5 tests	Pass
6.4.5A	Flushing of toilet paper	All 12 sheets flushed out in at least 4 of 5 tests	Ok 4 of 5 tests	Pass
6.4.6A	Flushing of fifty small plastic balls	Minimum of 42 balls flushed out each time	Ok 5 of 5 tests	Pass
6.4.6B	Flushing of forty small plastic balls	Minimum of 21 balls with a mass of 2.6 g flushed out each time	Ok 5 of 5 tests	Pass
6.4.7	Flushing of sponges	All 4 sponges flushed out in at least 4 of five tests	Ok 4 of 5 tests	Pass
6.4.8	Check on splashing	Not more than eight small drops of water beyond the rim	Ok 3 of 3 tests	Pass
6.4.10	Check on water seal level	Minimum 50 mm	63 mm	Pass

Table 8 Scandi I WCS disabled, reduced flush

<i>Test no.</i>	<i>Test method</i>	<i>Requirement</i>	<i>Scandi I WCP</i>	<i>Result</i>
Reduced flush	NT-VVS 120			
6.4.3	Total volume of flushing water, average and max difference	Flush volume below 6 l, lower than main flush. Tolerance of ± 0.3 litres	3.05 ± 0.12 l	Pass
6.4.4	Rinsing capacity	No sawdust left in the bowl	Ok 5 of 5 tests	Pass
6.4.5B	Flushing of toilet paper	All 4 sheets flushed out in at least 4 of 5 tests	Ok 4 of 5 tests	Pass
6.4.8	Check on splashing	Not more than eight small drops of water beyond the rim	Ok 3 of 3 tests	Pass
6.4.9	Exchange of water content of the trap	NaCl concentration equal to or less than 10 % of the reference concentration	< 10 %	Pass
6.4.10	Check on water seal level	Minimum 50 mm	63 mm	Pass

RISE Research Institutes of Sweden AB
Energy and circular economy - Sustainable Supply Systems and Plastic Products

Performed by

Examined by

Jonas Hansson

Thomas Ljung

Appendices

1. Drawings of the Water closets
2. Photos of the new distributor
3. Correct setting of the flushing valve

Appendix 1

Drawing of Scandi I WCS, article no. FS1PKW9500000

08.11.2017

Page 3 of 16

QR of Scandi I Combination Concealed Shrouded WCS

Section 2: Technical Drawing

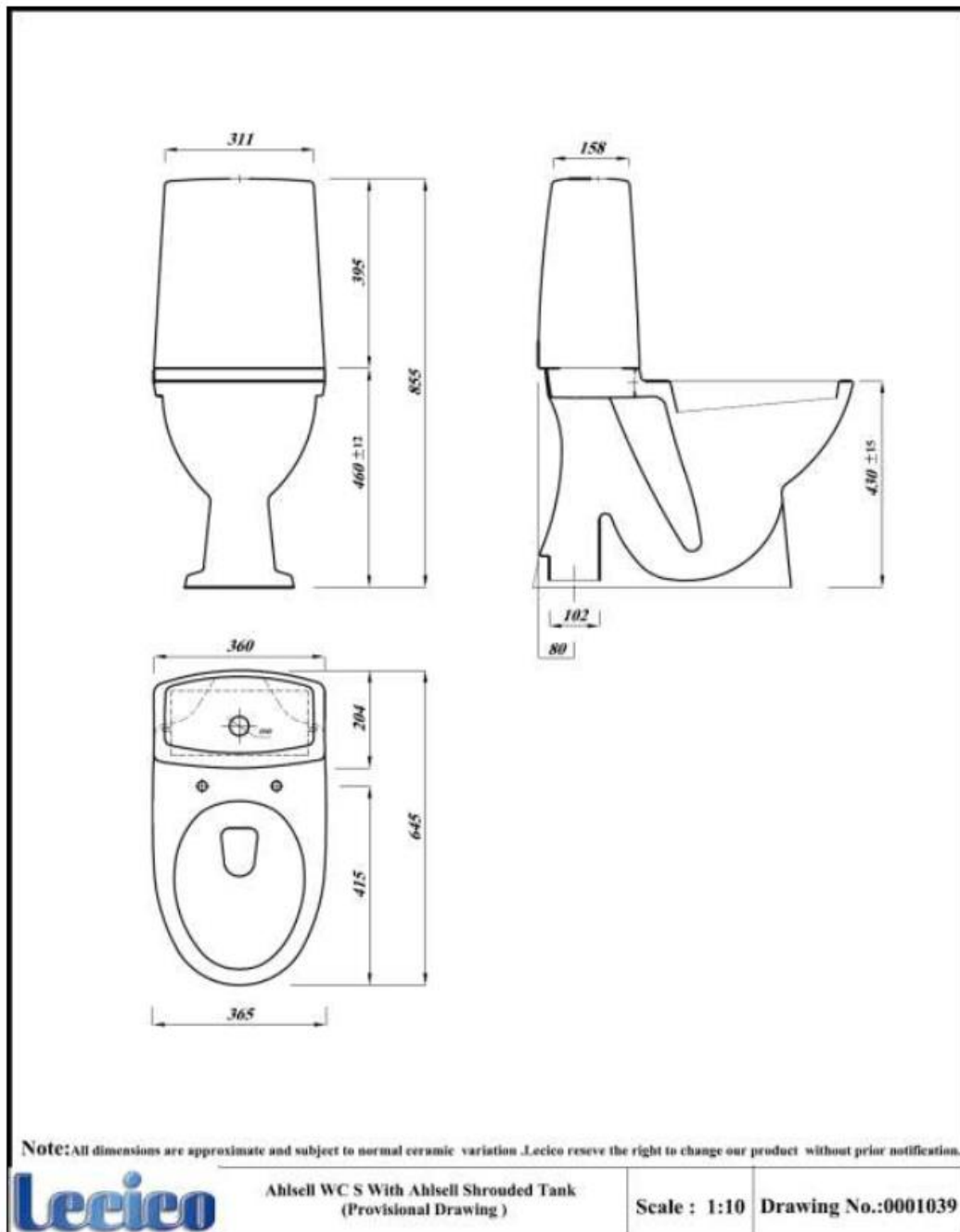

Appendix 1

Drawing of Scandi I WCP, article no. FS1PKW9600000

11.11.2017

Page 3 of 15

QR of Scandi I Combination Concealed Shrouded WCP

Section 2: Technical Drawing

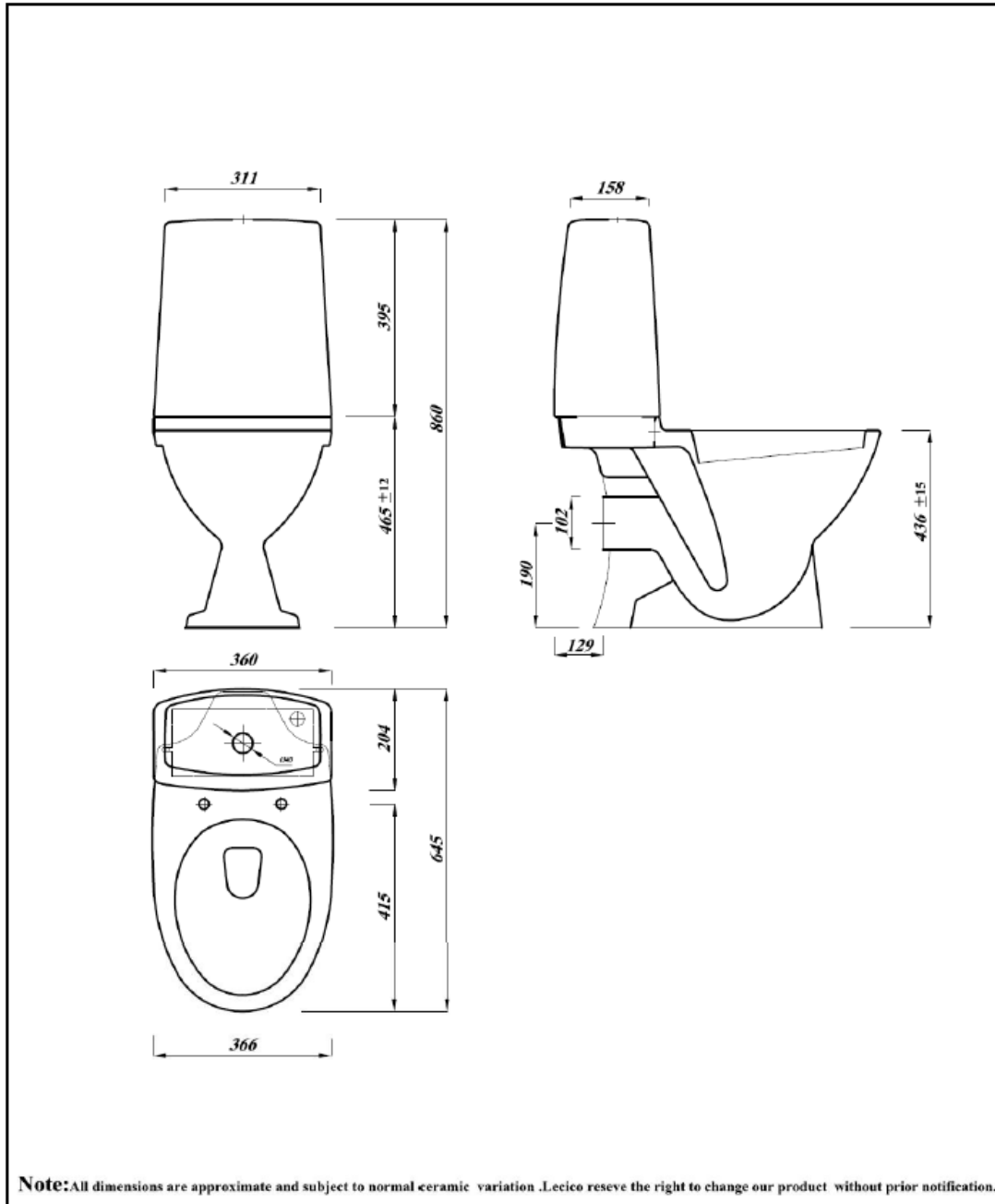

Appendix 1

Drawing of Scandi I WCS disabled, article no. FS1PKW97000000

08.11.2017

Page 3 of 16

QR of Scandi I Combination Disabled concealed Shrouded WCS

Section 2: Technical Drawing

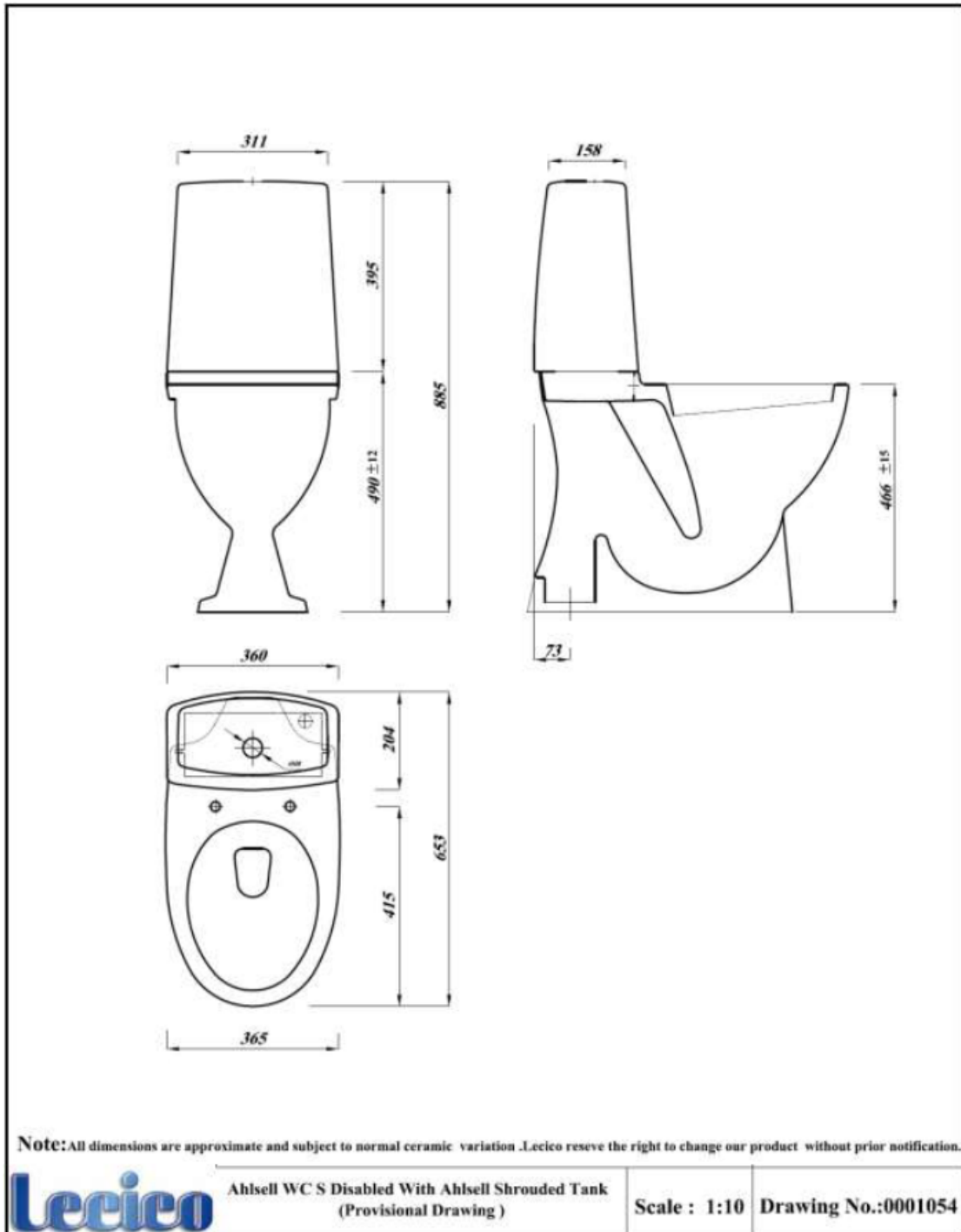

Appendix 2

Photos of the new distributor



Appendix 3

Correct setting of the flushing valve